

Instruction sheet for adjustable rear rifle sight.

(For 1" and 1-1/8" barrels)

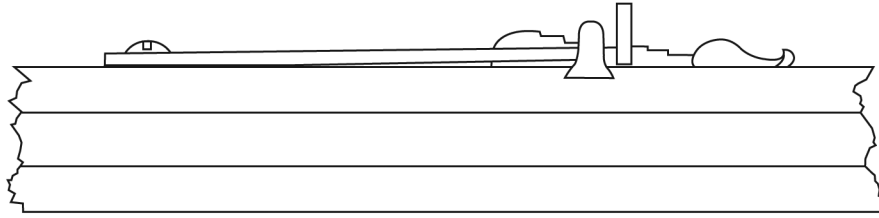

1. Carefully remove the casting gates with a file on the sight, ramp, and dovetail adjuster.
2. Drill a 1/8" hole on the center punch mark, located at the muzzle end (rounded end) of the sight.

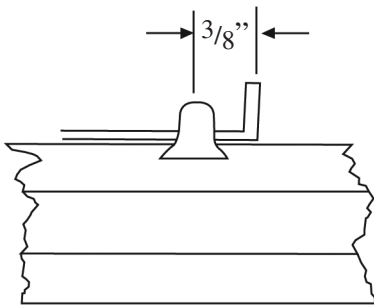

3. Cut a dovetail slot across the barrel 3/8" forward of the point you want the rear face of the sight to be located. We recommend the dovetail be set to a depth of .060" to .090". The fit of the dovetail adjuster to the barrel should be a light press fit as this will be your windage adjustment.

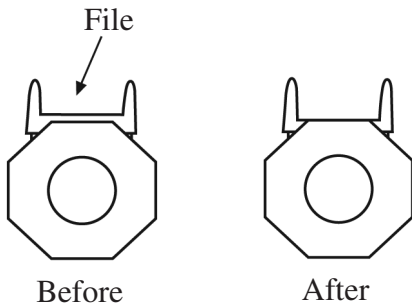

4. File the excess metal between the two upright posts on the dovetail adjuster down to the top flat of the barrel taking care not to widen the distance between the posts.

5. Clamp the sight base on the barrel in the proper location. Center mark the location of the 1/8" drilled hole on the sight to the barrel. Drill a blind hole in the barrel with a #38 tap drill 5/32" deep on this mark. Measure carefully so you do not drill into the bore. Tap the hole with a 5-40 bottom tap.
6. Screw the sight base to the barrel, and fit the sight riser to the sight base, and your sight is installed.

Track of the Wolf, Inc.

18308 Joplin Street N.W.

Elk River, MN 55330-1773

Tel: 763-633-2500

Fax: 763-633-2550

<http://www.trackofthewolf.com>